

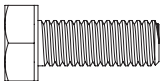
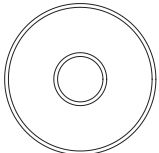
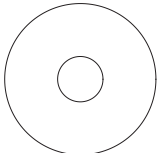
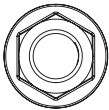
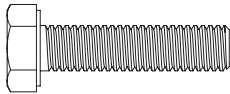
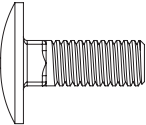

IN8086

ULTI Bars - X3

FX4012 X12 (M6X16) 	FX4013 X24 (M6) 	FX4014 X24 (RUBBER) 	FX4016 X24 (M6) 	FX4021 X12 (M6X25) 	FX4042 X12 (M6X16) 	MA6019 X2 	MA6020 X6 
MA6065 X6 	ME0203 X6 	ME0729 X1 	ME0730 X1 	ME0731 X2 	ME0732 X1 	ME0733 X1 	AS3208 X3 

TOOLS REQUIRED

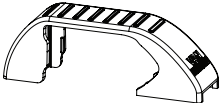
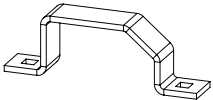
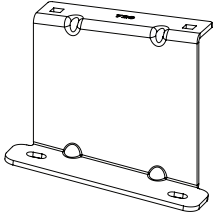
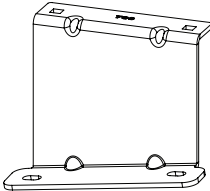
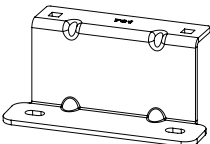
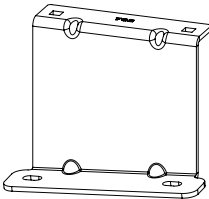
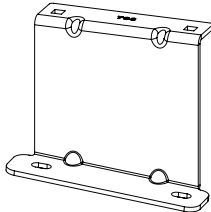
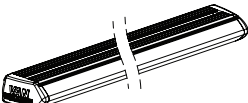
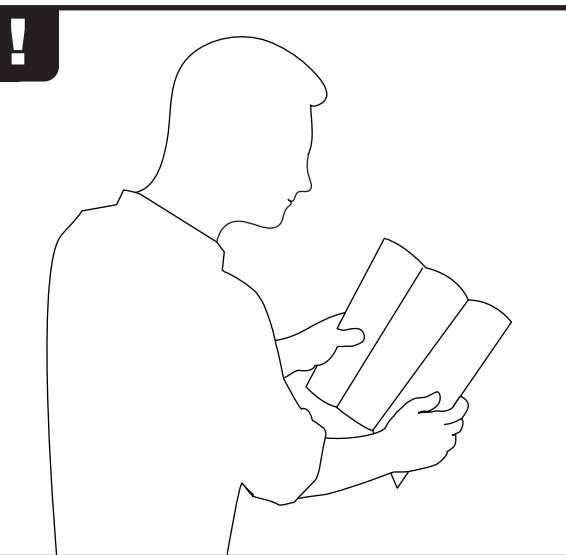

GB. Maximum load per roof bar = 55kg. Maximum load is in accordance with the vehicle manufacturer's load bearing capacity (refer to the vehicle handbook). **Do not exceed this limit.**



FR. Poids maximum par barre de toit = 55kg. La charge maximale doit être conforme à la capacité de charge du constructeur de véhicule (veuillez- vous référer au livret du véhicule). **Ne dépassez pas cette limite.**



DE. Maximallast pro Dachträger = 55kg. Die Maximallast steht im Einklang mit der angegebenen Ladekapazität des Fahrzeugherstellers (diese finden Sie im Fahrzeughandbuch). **Die Maximallast darf nicht überschritten werden.**



DK. Maksimum last pr tagbøjle = 55kg. Maksimal lasteevne afhænger af varevognproducents angivelser i varevognens håndbog. **Overskrid ikke denne grænse.**

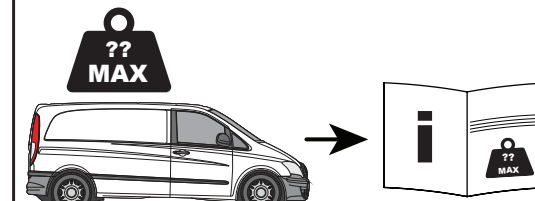
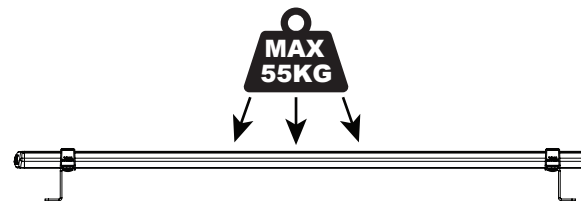

This FITTING INSTRUCTION is the property of VAN GUARD ACCESSORIES LTD. and must not be used for manufacturing purposes, copied nor communicated in any way to third parties without written permission from VAN GUARD ACCESSORIES LTD.
IN8086_C - IW - 09/01/2017

Van Guard Accessories Ltd
Fair Oak Close, Exeter Airport Business Park,
Exeter, Devon, EX5 2UL
www.van-guard.co.uk

VG264-3

Vehicle:
Mercedes Vito: 2004 on
Wheel Base: Compact (L1)
Roof Height: Low (H1)
Rear Doors: Twin / Tailgate

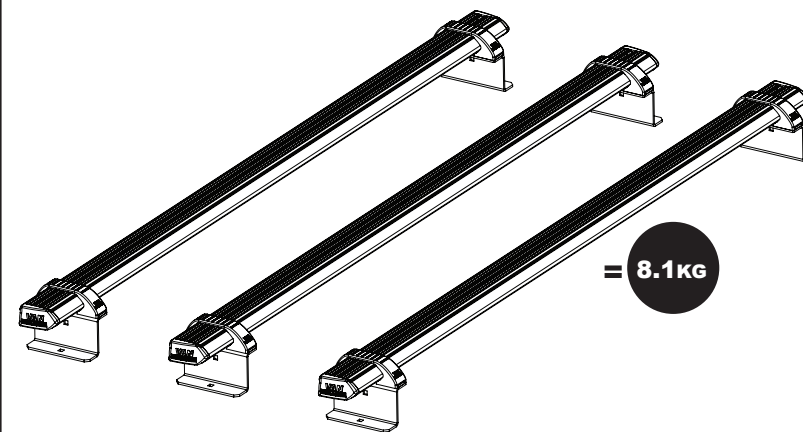
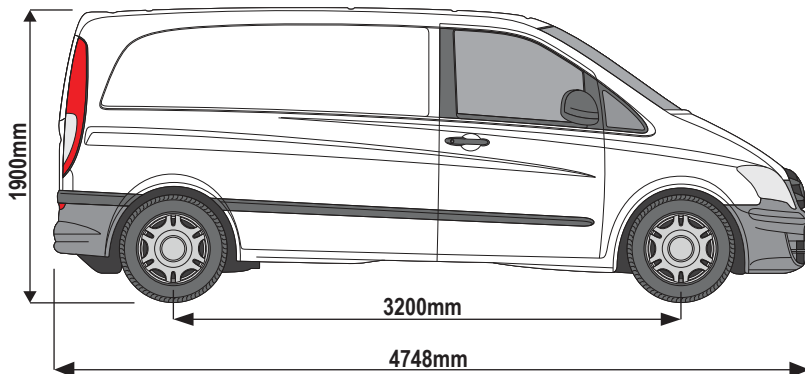

VG264-3

Vehicle:
Mercedes Vito: 2004 on
Wheel Base: Long (L2)
Roof Height: Low (H1)
Rear Doors: Twin / Tailgate

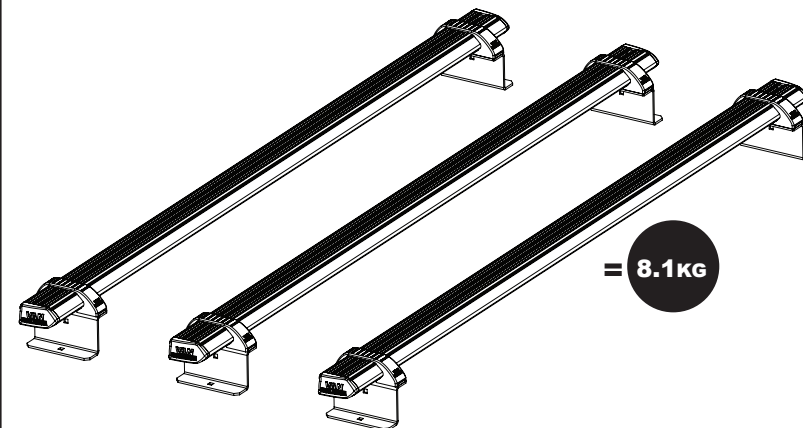
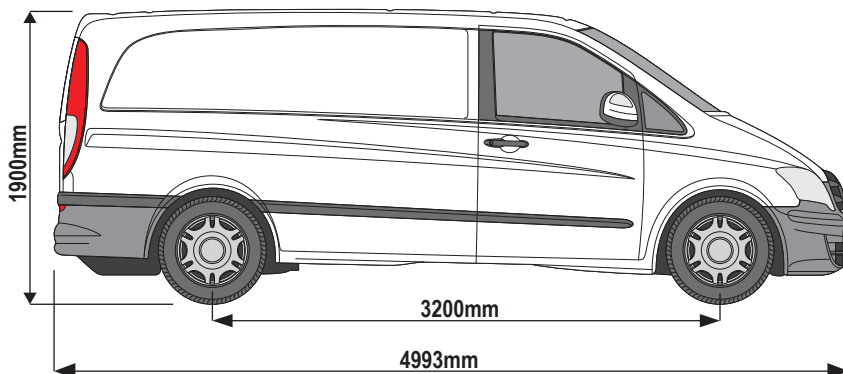

VG264-3

Vehicle:
Mercedes Vito: 2004 on
Wheel Base: Extra Long (L3)
Roof Height: Low (H1)
Rear Doors: Twin / Tailgate

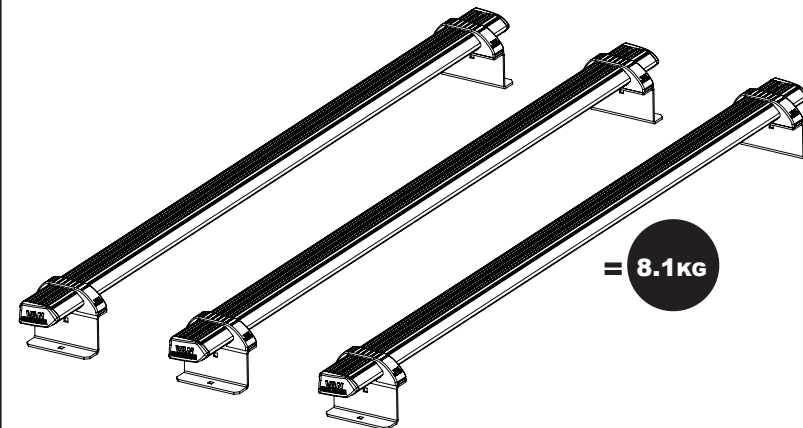
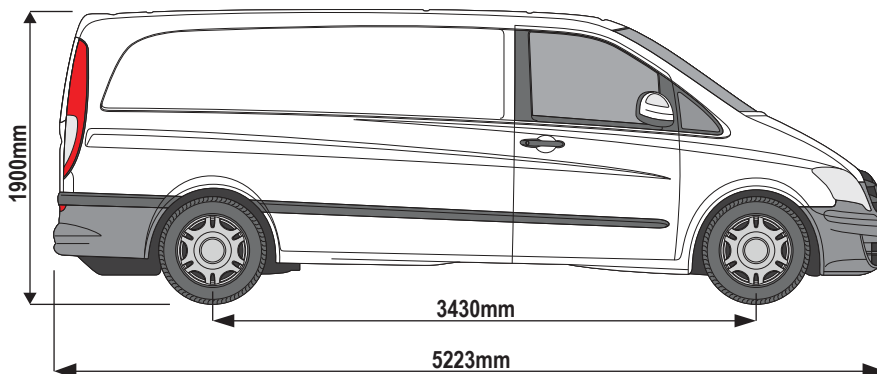

1

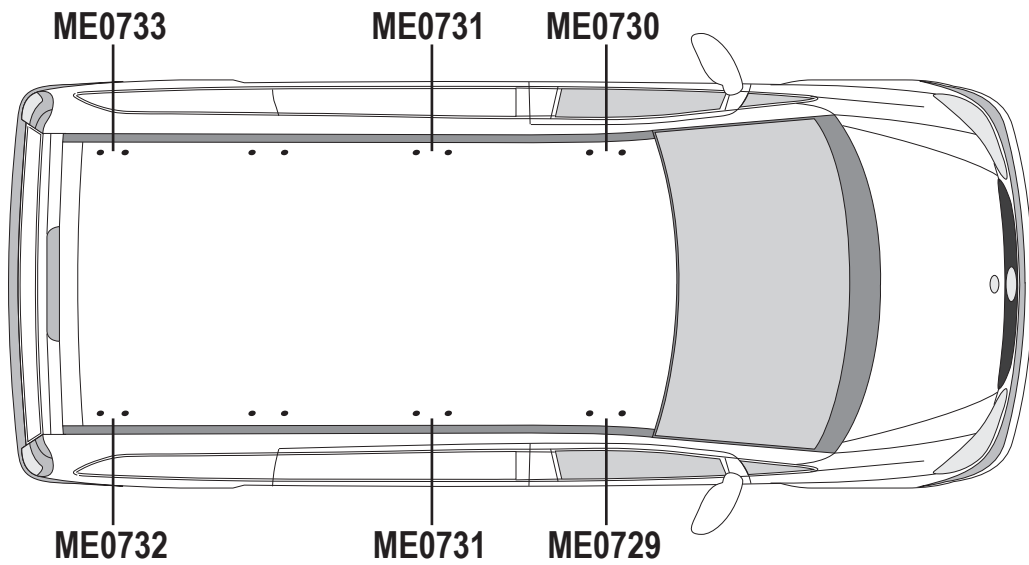

ME0729

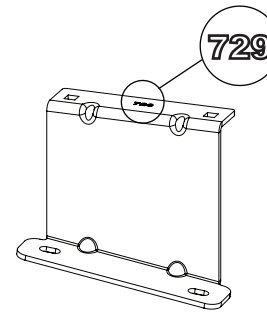

ME0730

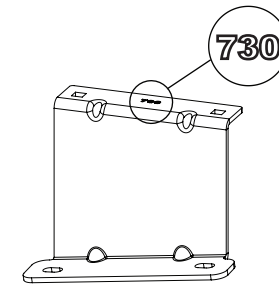

ME0731

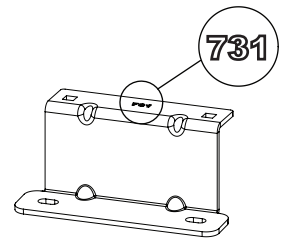

ME0732

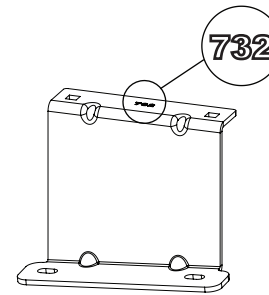

ME0733

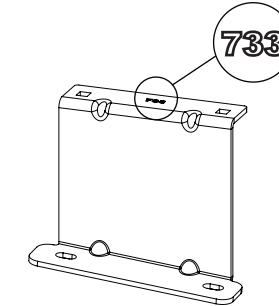

2

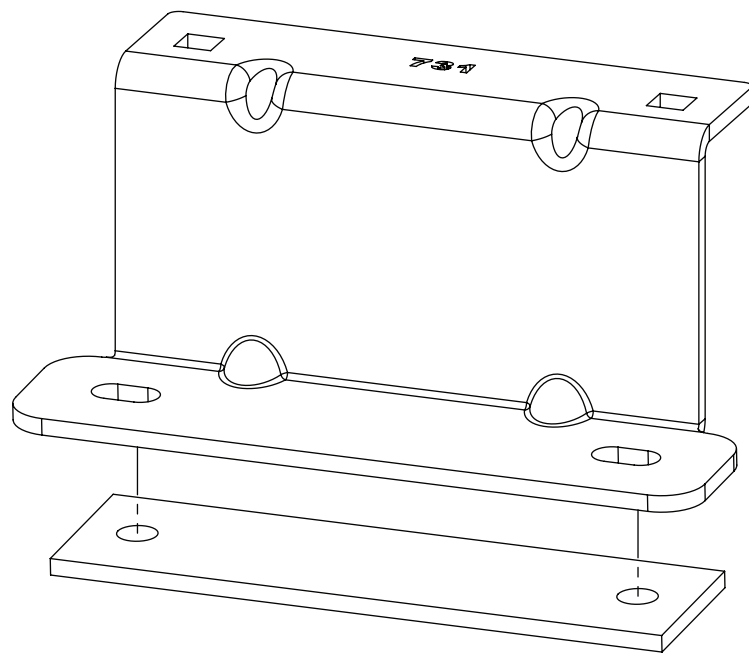

3

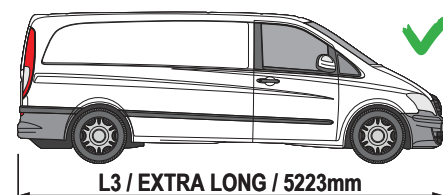
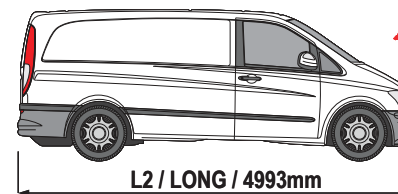
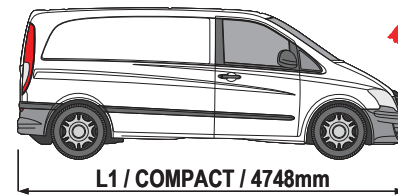

ME0732

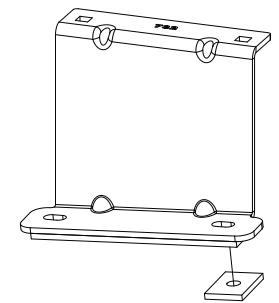

ME0733

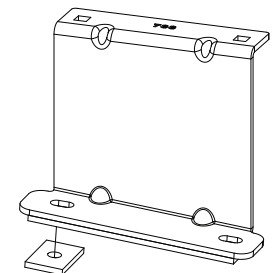

4

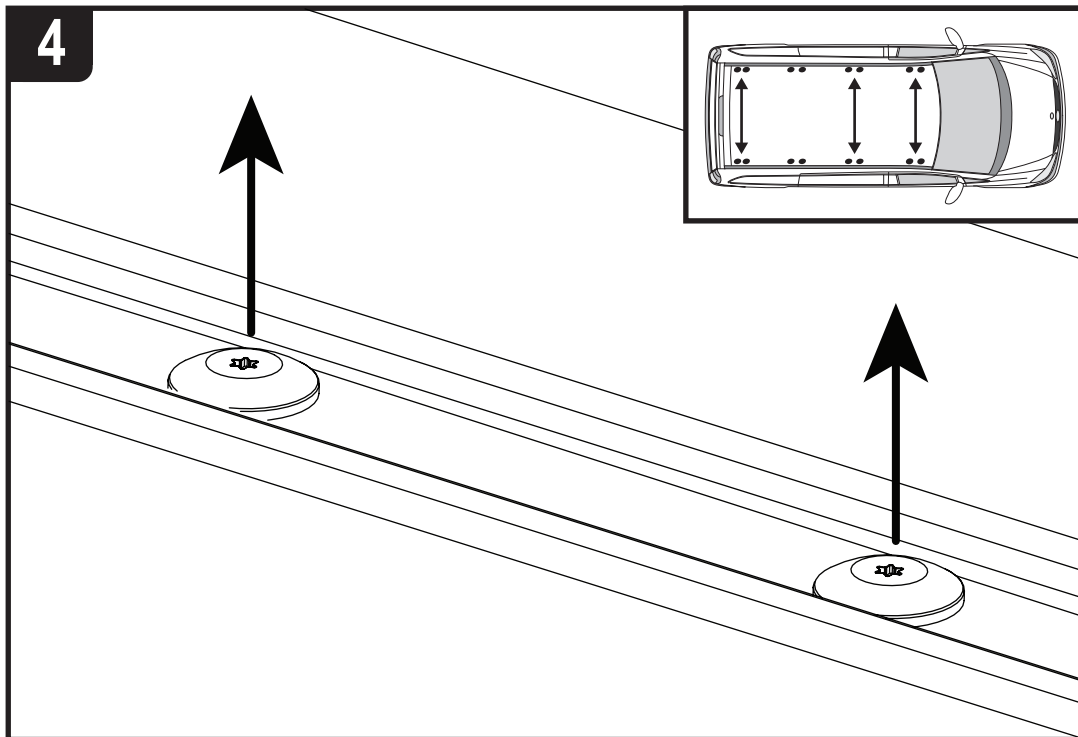

5

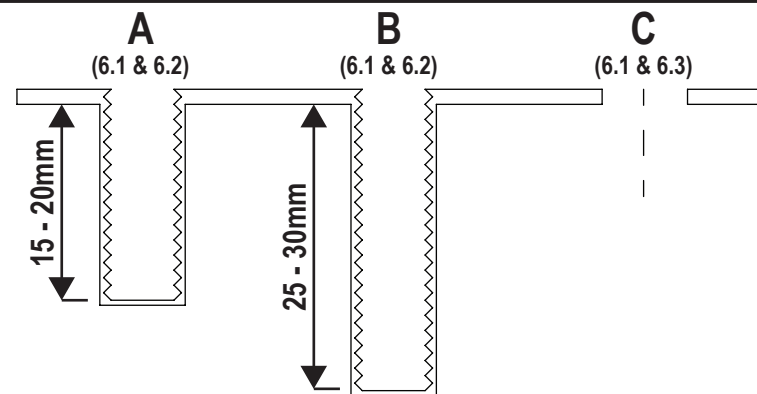

GB: Check the vehicles fixing points to determine which type you have (A, B or C) and follow the relevant steps.



FR: Vérifiez les véhicules deux points de fixation Déterminer le type de som vous avez la (A, B ou C) et suivez les étapes appropriées.



DE: Schauen Sie sich die Fahrzeuge Punkt zu befestigen, um zu bestimmen qui wie Sie-haben (A, B oder C) und die entsprechenden Schritte folgen.



DK: Tjek de køretøjer, fastsættelse af punkt til at bestemme qui ligesom du-have (A, B eller C) og følge de relevante trin.

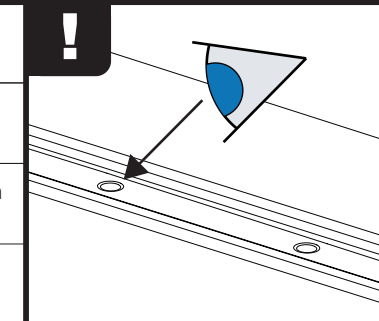

6.1

A + B + C

FX4014
(RUBBER)

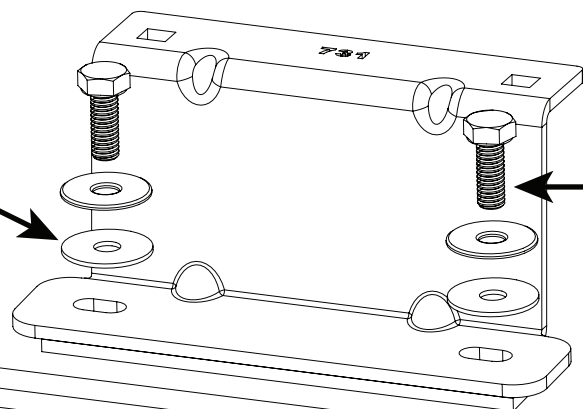

A = M6X16
B = M6X25
C = M6X25

6.2

A + B

8Nm

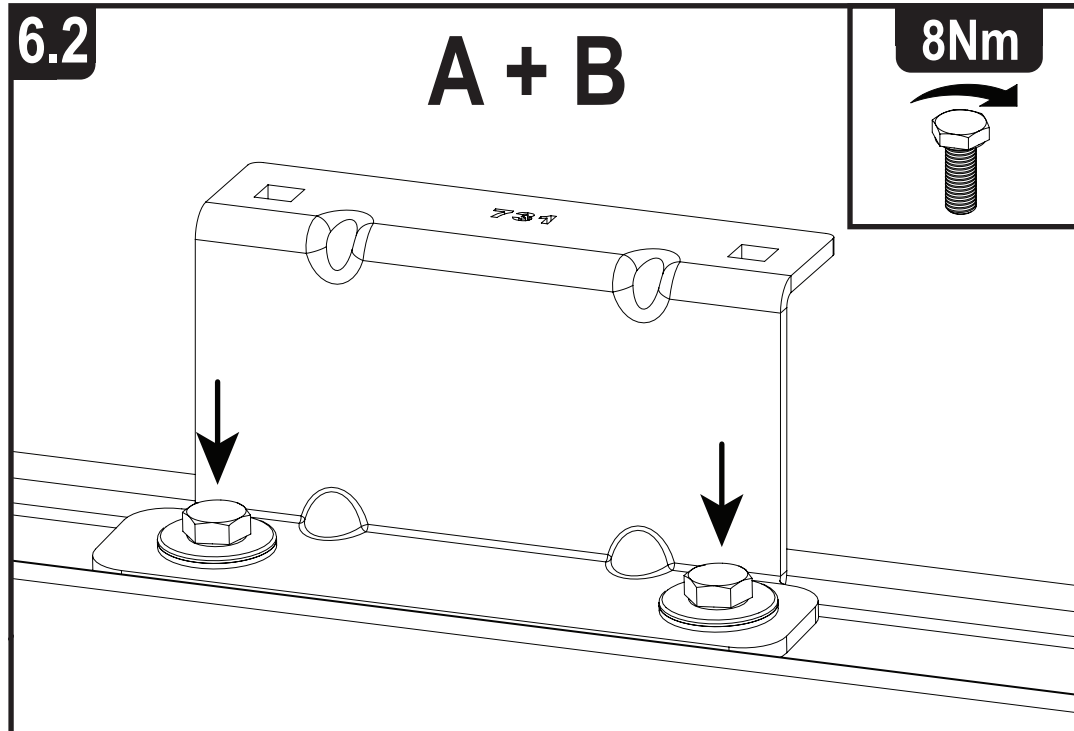

6.3

C

8Nm

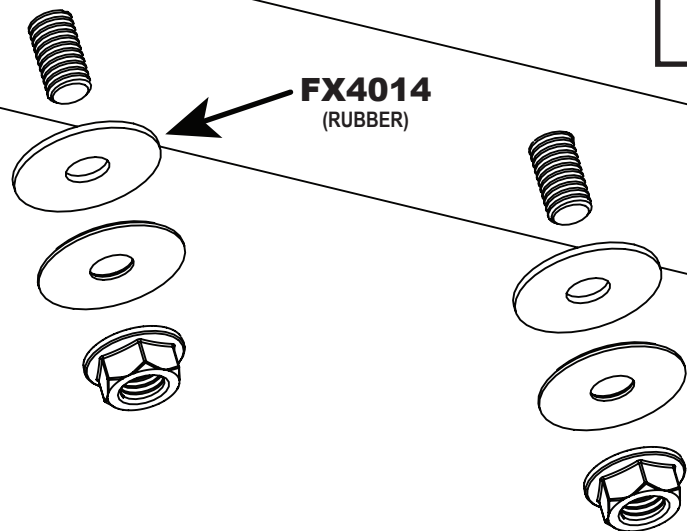
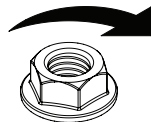

FX4014
(RUBBER)

7

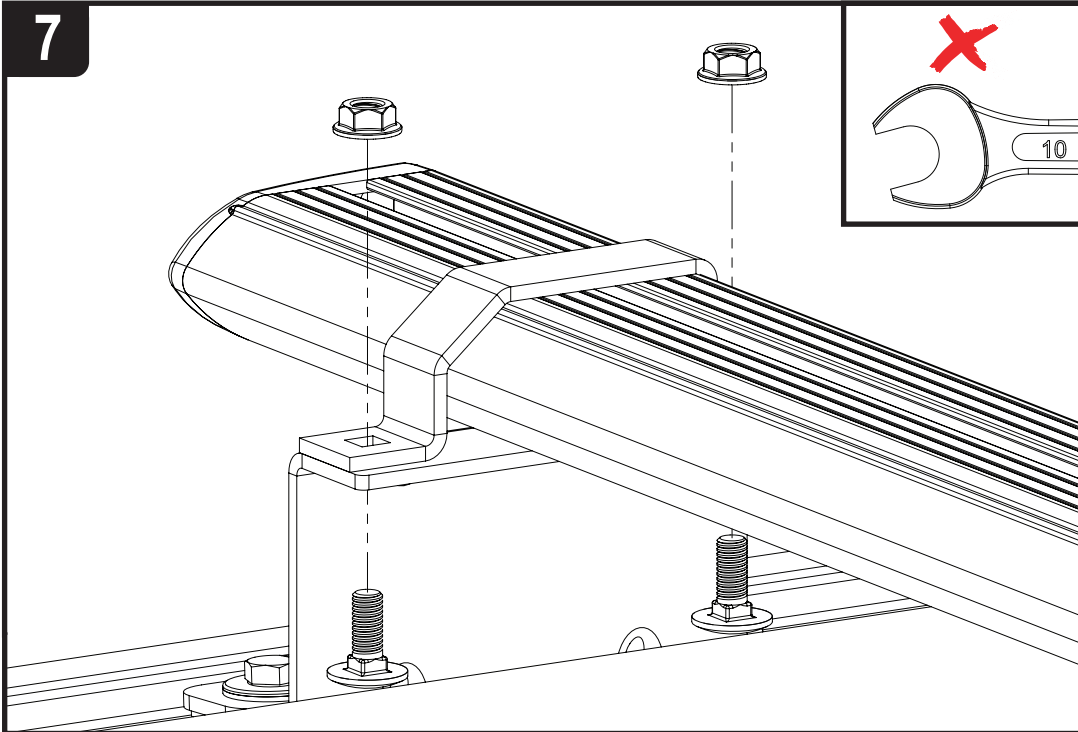

X

10

8

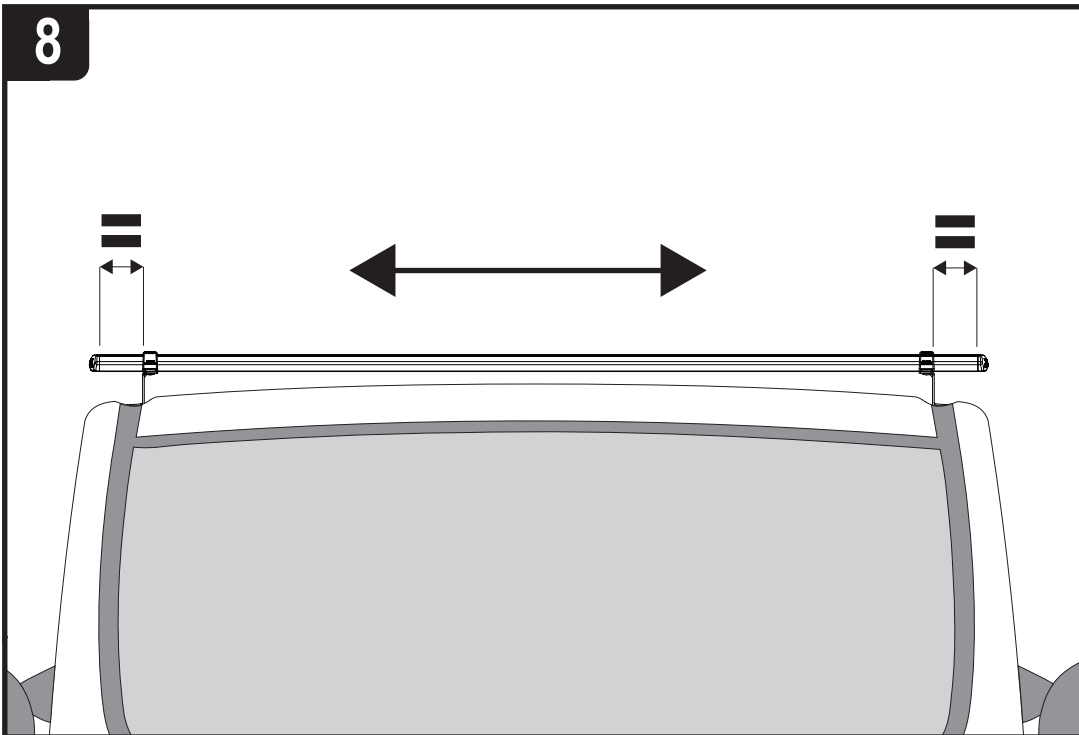

9

8Nm

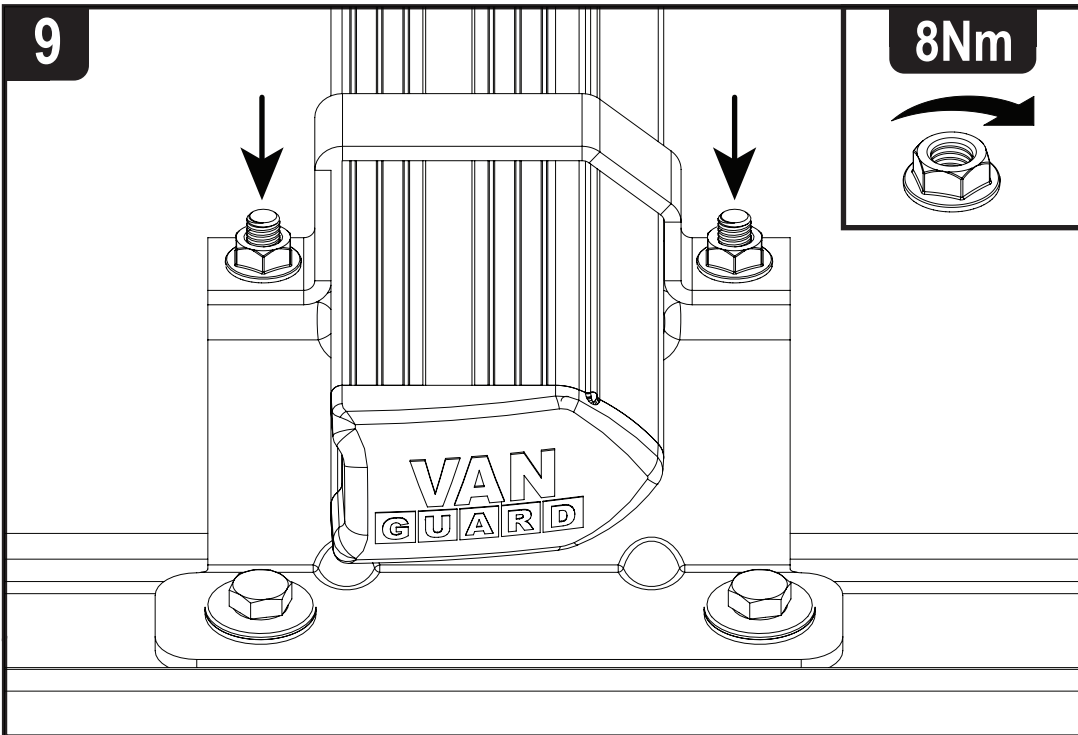
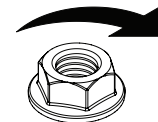

1.

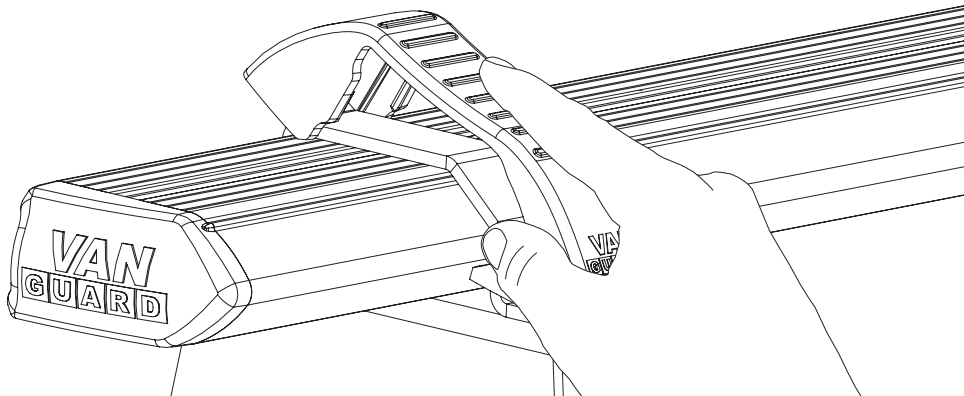

2.

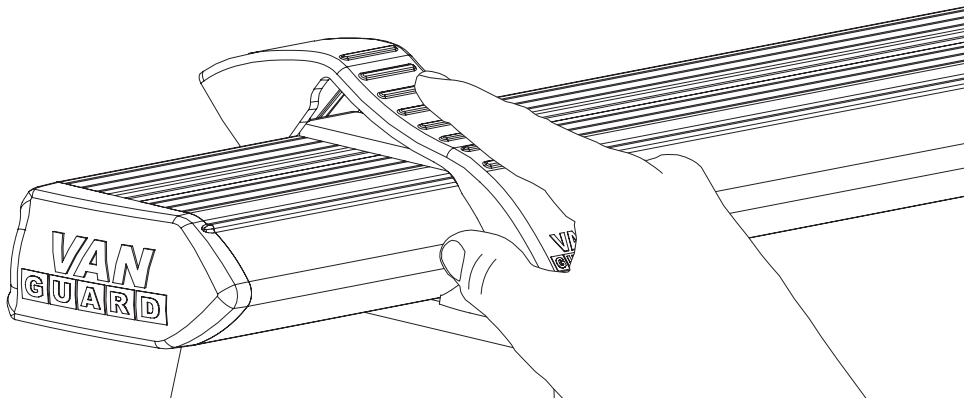

3.

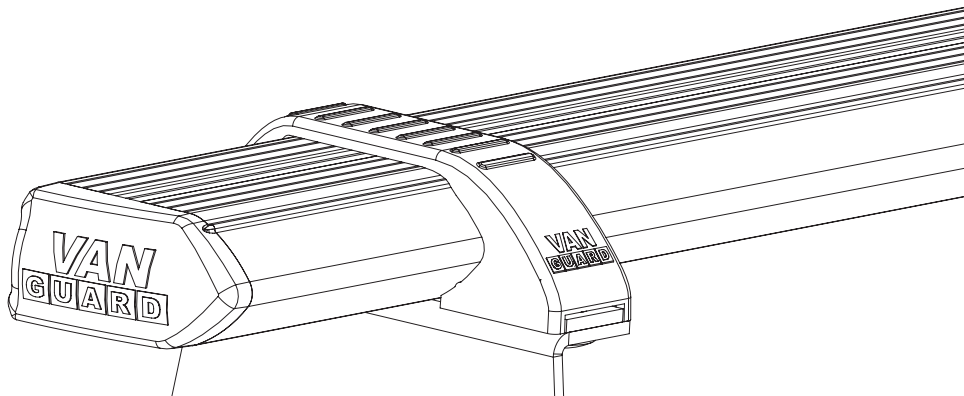

GB

1. Regularly inspect all fixings and parts. Any damaged or worn parts should be immediately removed from the vehicle and replaced.
2. Take care when loading and unloading goods on to and off the vehicles roof.
3. Van Guard Accessories LTD and/ or its distributors do not accept liability for:
 - Any products that have been fitted incorrectly.
 - Any products which have been fitted to the incorrect vehicle.
 - Any products that have been modified in any way or are being used for any purpose that they are unintended for.
4. It is important that the end user receives this document and that instructions are retained for future use.



FR

1. Inspecter régulièrement toutes les fixations et les pièces. Les pièces endommagées ou usées doivent être immédiatement retiré du véhicule et remplacé.
2. Prendre garde lors du chargement et du déchargement de marchandises vers et hors des véhicules toit.
3. Van Guard Accessoires Ltd et/ ou ses distributeurs n'accepte pas de responsabilité pour:
 - Les produits qui ont été ajustés de manière incorrecte.
 - Les produits qui ont été montés sur le véhicule incorrect.
 - Les produits qui ont été modifiés de quelque façon ou sont utilisés à toutes fins qu'ils sont involontaires.
4. Il est important que l'utilisateur final reçoit ce document et que les instructions soient conservés pour une utilisation futur.



DE

1. Prüfen Sie regelmäßig alle Befestigungen und Teile. Alle verschlissenen oder beschädigten Teile sollten sofort aus dem Fahrzeug ausgebaut und erneuert.
2. Vorsicht beim Be- und Entladen von Gütern auf und abseits der Fahrzeuge.
3. Van Guard Accessories LTD und/ oder seinen Händlern keine Haftung für:
 - Sämtliche Produkte, die falsch montiert worden.
 - Alle Produkte, die auf die falsche Fahrzeug.
 - Alle Produkte, die nicht in irgendeiner Weise verändert oder verwendet für jeden Zweck, sie sind unbeabsichtigt.
4. Es ist wichtig, dass der Endbenutzer erhält dieses Dokument und die Anweisungen für eine zukünftige Verwendung aufbewahrt werden.



DK

1. Undersøg med jævne mellemrum alle løsdele og fæstninger. Beskadigede eller slidte dele bør straks fjernes fra køretøjet og repareres eller erstattet.
2. Vær meget opmærksom ved lastning og losning af varer fra varevognens tag.
3. VanGuard Accessories Ltd og/eller deres distributører accepterer ikke ansvar for:
 - Produkter der ikke er monteret korrekt som angivet i monteringsvejledning.
 - Produkter der er blevet monteret på et køretøj, de ikke er beregnede til.
 - Produkter der er blevet modificerede på nogen måde eller bliver brugt på en måde, hvortil de ikke er beregnede.
4. Det er vigtigt, at dette dokument overdrages til slutbruger af produktet og at vejledning er gemt til senere brug.