

# VG43-3

## 3 Heavy duty aluminium roof bars - Vauxhall Astra Van pre September 2006

### SUPPLIED COMPONENTS

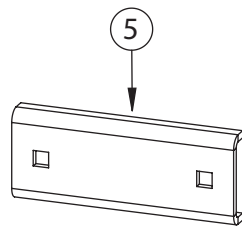
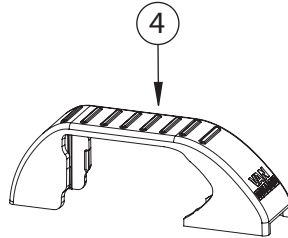
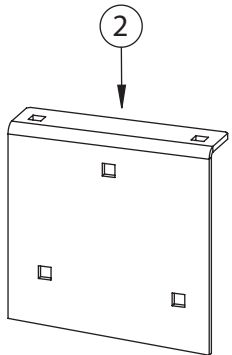
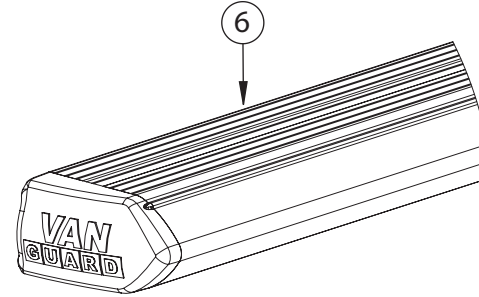
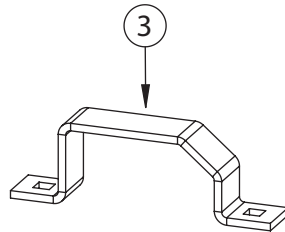
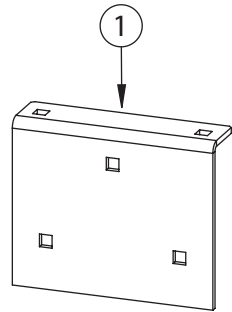

#	DESCRIPTION	QTY
1	REAR / MIDDLE ROOF BRACKET	4
2	FRONT ROOF BRACKET	2
3	TOP HAT	6
4	TOP HAT COVER	6
5	FIXING BRACKET	6
6	ROOF BAR	3

### SUPPLIED FIXING KIT

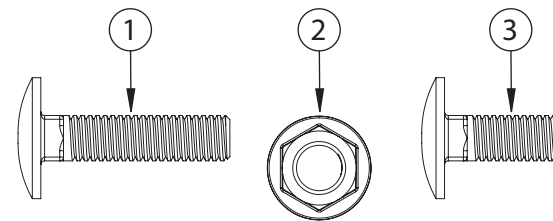

#	DESCRIPTION	QTY
1	M6x25 COACH BOLT	12
2	M6 SERRATED FLANGE NUT	24
3	M6x16 COACH BOLT	12

TOOLS REQUIRED: 10mm SPANNER / RATCHET

This FITTING INSTRUCTION is the property of VAN GUARD ACCESSORIES LTD. and must not be used for manufacturing purposes, copied nor communicated in any way to third parties without written permission from VAN GUARD ACCESSORIES LTD.  
IN8124\_A - IW - 03/05/2013

Van Guard Accessories Ltd  
Fair Oak Close, Exeter Airport Business Park,  
Exeter, Devon, EX5 2UL  
www.van-guard.co.uk

**1** The front roof brackets are handed to suit both sides of the vehicle and are angled to suit the slope of the roof.

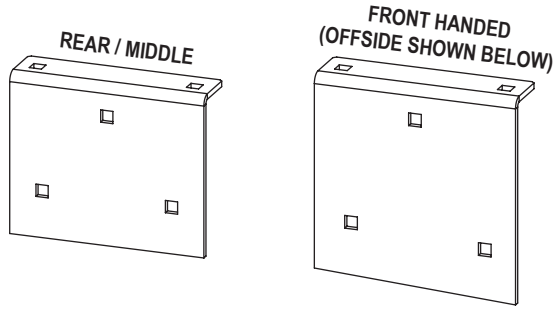

**2** Loosely secure the roof bars onto the roof brackets using top hat brackets, M6x16 coach bolts & M6 serrated nuts. Ensure that the roof bar inserts are facing upwards.

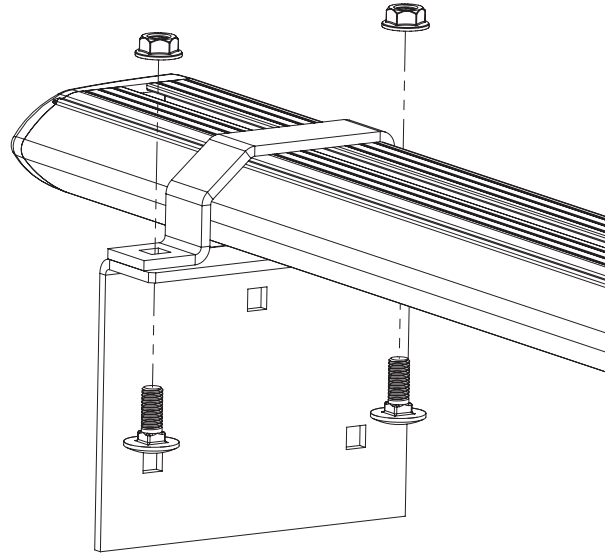

**3** Slide the plastic covers on the van roof open to expose the roof fixing rail. If the van roof doesn't have plastic covers use the existing roof rail to clamp the roof brackets to.

Place assembled roof bars onto the vehicles roof and clamp the roof brackets to the vehicles side rail using M6x25 coach bolts, fixing brackets & M6 serrated nuts.

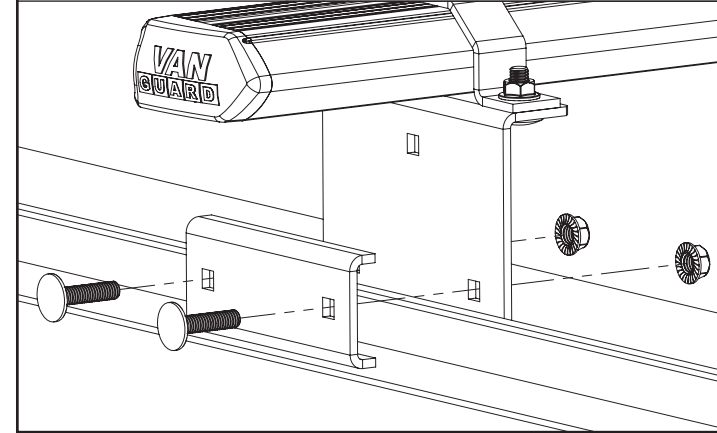

**4** Flex the top hat covers over the top hat brackets into position as shown below. Ensure that the covers click into the front and rear of the top hat brackets.

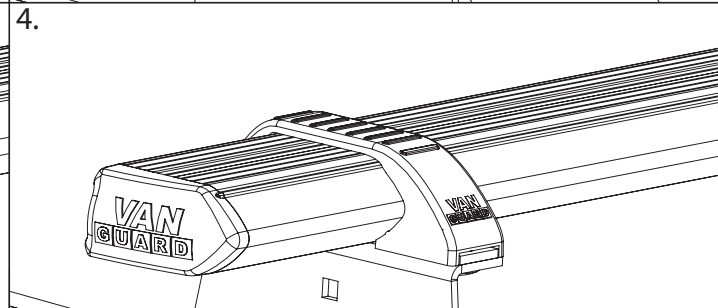
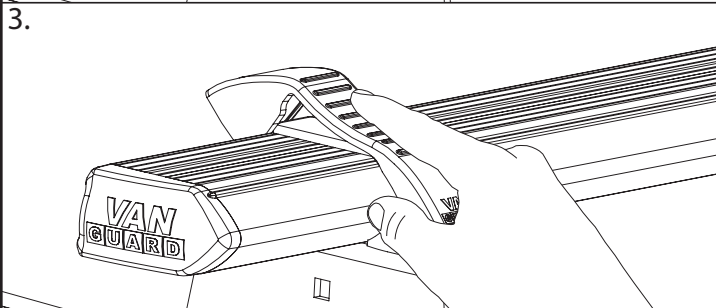
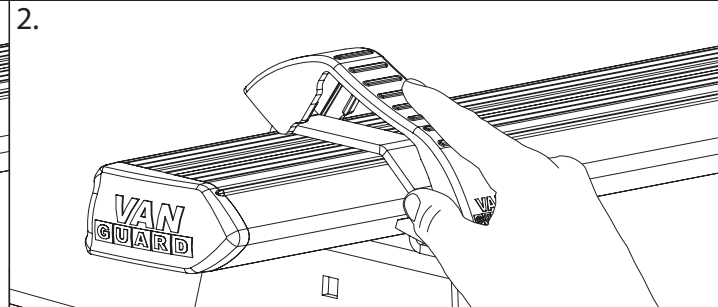
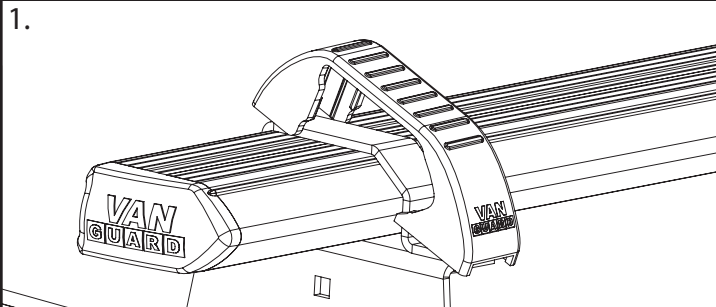

**5** Once in position tighten all fixings to 8Nm. Periodically check all fixings.



**TIGHTEN TO 8Nm**

**NOTES:**

Maximum load is 55kg per bar. Please check that the vehicle manufacturers load bearing capacity for the roof is not exceeded. (Refer to the vehicle handbook)

Periodically check all fixings.

Retain these instructions for future reference.