

VG103

Van Guard Ladder Securing Clamps - Universal

SUPPLIED COMPONENTS

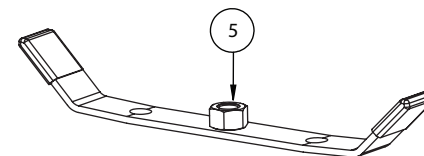
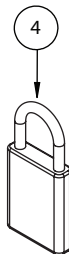
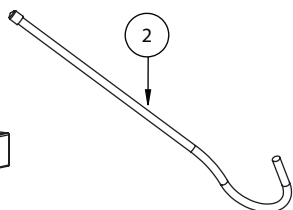
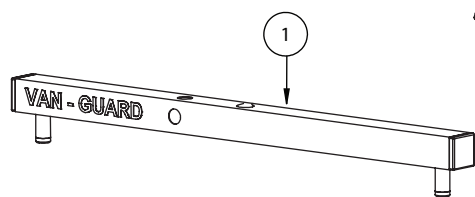

#	DESCRIPTION	QTY
1	BOX SECTION	2
2	THREADED HOOK	2
3	WASHER	2
4	PADLOCK	2
5	HANDLE	2

1 Assemble the components together as shown below to make two ladder clamps.

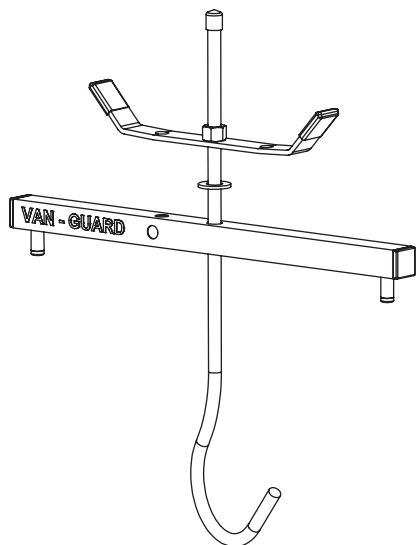

2 To secure a ladder, place ladder clamp in position with the two spigots on the outside and secure by spinning the handle down, clamping the box section to the ladder. **Be careful not to overtighten.**

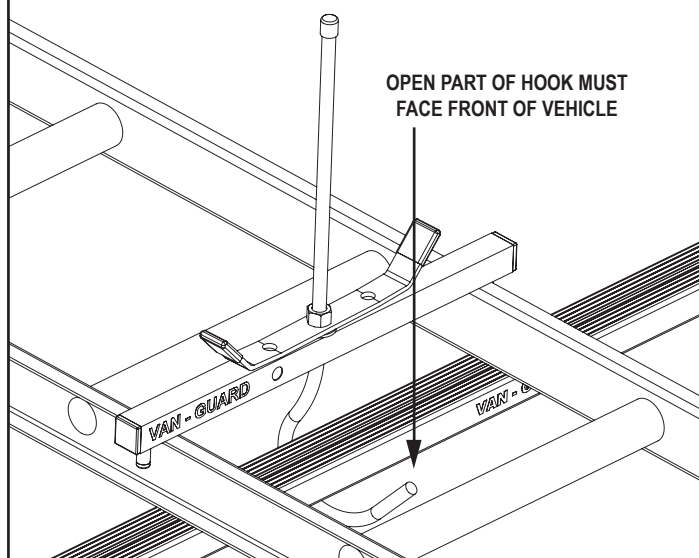

3 For security align the holes on the box section with the holes on the handle and use a padlock to lock them together (as shown below).

Ensure that the open end of the hook is facing towards the front of the vehicle.

Always use two clamps, one at the front and one at the rear.

Regular lubrication of the thread will prolong the life of the clamp.

