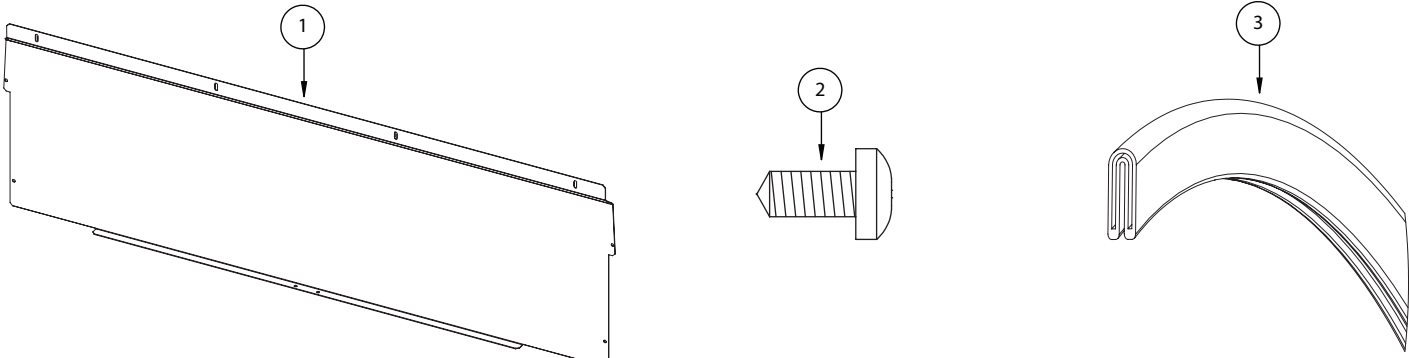

SUPPLIED COMPONENTS	ITEM NO.	DESCRIPTION	QTY
 <p style="text-align: right;">TOOLS REQUIRED SCREW DRIVER, DRILL, DRILL BIT</p>	<p>1</p> <p>2</p> <p>3</p>	<p>BULKHEAD</p> <p>No14 x 1/2" SELF TAP SCREW</p> <p>RUBBER EDGING</p>	<p>1</p> <p>6</p> <p>1</p>

IMPORTANT NOTES:

* Whilst every effort has been made to ensure our products can be safely fitted, if any product requires drilling in to the vehicle, we ask you to check that there is no possibility of causing damage when fitting. Make sure drilled holes do not conflict with any wiring, pipes, fuel tanks or spare wheels etc. Changes to the van sometimes occur, so it's always good practice to check before drilling as we cannot except responsibility for any damage caused by the fitting of any of our products. (When drilling always wear safety glasses.)

* Periodically check all fixings.

* Retain instructions for future use.

INSTRUCTIONS

Please read the important notes to the left before fitting this product.

Step 1: Place bulkhead into the van with the returns facing into the load area.

Step 2: Drill 4.5mm diameter through the bulkhead holes into the skin of the door pillars and floor. Fix in place using the **short** screws. **When drilling be sure to only drill through the single skin of the van and no further.**

Step 3: Fit rubber edging to the exposed top edge.

